

# MAG300 Analog

## MAGNETOSTRICTIVE SENSOR

Absolute measuring length up to 2.5 m linear position transducer



L.4 - DS0024 R02 MAG300 Analog - 06/11/24



### CHARACTERISTICS

Measuring range up to 2.5 m
Designed for integration into hydraulic cylinders
High shock and vibration resistance
Plug-in flange
Operating pressure up to 350 bar
Customizable cursor



### ADVANTAGES

Absolute contactless linear position measurement
High resolution and linearity
Unlimited mechanical life
Rod, nipple and flange in AISI 316
Simple integration in cylinders with M12 plug-system
Position, speed and acceleration measurement



High protection level



Shock/vibration resistant

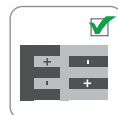

Reverse polarity protection

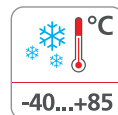

Wide temp. range

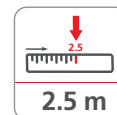

Max. length: 2.5 m



Analog output



High accuracy



Directive 2011/65/EU



EU conformity

The company reserves the right to make any kind of design or functional modification at any moment without prior notice.

# MAG300 Analog

## MAGNETOSTRICTIVE SENSOR

Absolute measuring length up to 2.5 m linear position transducer



### PRODUCT DESCRIPTION

MAG300 is a magnetostrictive position transducer with flange connection, designed for mobile machines which can be completely installed inside oil-pressure cylinders. Its unique design, plus a wide range of cursor configurations, ensures easy installation and full compatibility with cylinder manufacturer specifications.

The temperature range from -40 to +85°C, the operating pressures up to 350 bar and the high resistance to vibration and shock make the sensor very robust, a fundamental feature in heavy-duty applications.

High performance in terms of transduction of measurement defined as linearity, hysteresis and repeatability.

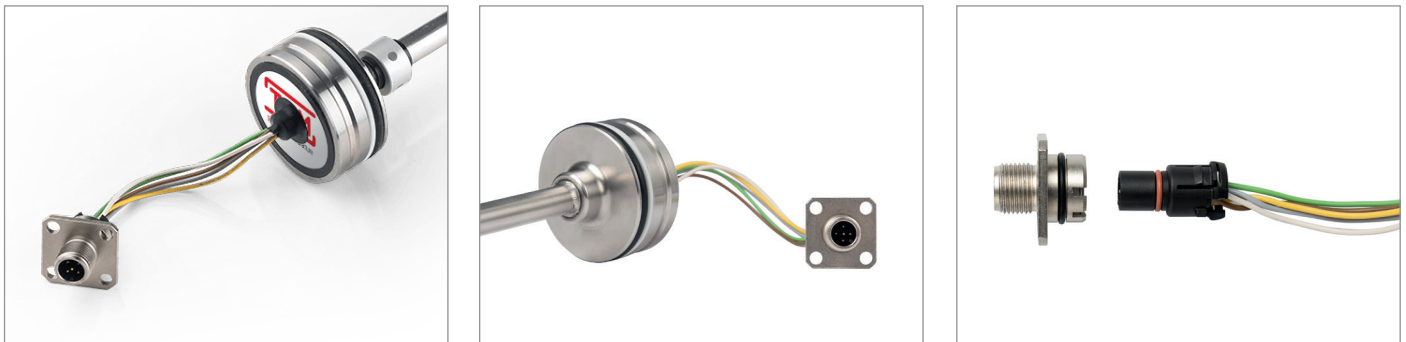

**Agricultural machinery**



**Construction**



**Earth moving**



**Handling and lifting**

L.4 - DS0024 R02 MAG300 Analog - 06/11/24

# MAG300 Analog

## MAGNETOSTRICTIVE SENSOR

Absolute measuring length up to 2.5 m linear position transducer



### PRODUCT CODE

**ORDER CODE<sup>(1)</sup>** ▶ **M A G 3 0 0 .** \_ . \_ \_ \_ \_ . \_ . \_ \_ . \_ \_ . \_ . \_ . \_ . \_

**a** Power supply range  
**2** ◀ = 9 ... 30 V DC (only for outputs 2; 33; 32; 34)  
**3** ◀ = 12 ... 30 V DC (only for outputs 7; 35; 4; 41)

**b** Active stroke range  
**XXXX** ◀ = mm (steps of 0100 mm)

**c** Dead zone  
**20** ◀ = 20 mm only for backwards compatibility  
**36** ◀ = 36 mm for 0 to 1200mm stroke  
**63** ◀ = 63 mm for 1201 to 2500mm stroke

**d** Output type<sup>(2)</sup>  
**2** ◀ = 0,5...4,5 VDC  
**33** ◀ = 4,5...0,5 VDC  
**32** ◀ = 0,25...4,75 VDC  
**34** ◀ = 4,75...0,25 VDC  
**7** ◀ = 4...20 mA  
**35** ◀ = 20...4 mA  
**4** ◀ = 0...10 VDC  
**41** ◀ = 1...9 VDC

**e** Connections  
**26A** ◀ = Plug system M12, 4-pin with wires 60mm  
**26B** ◀ = Plug system M12, 4-pin with wires 150mm  
**26C** ◀ = Plug system M12, 4-pin with wires 300mm  
**9** ◀ = Cable 5Mt 4x0,25mm<sup>2</sup> PUR/PVC  
**33** ◀ = Cable 7Mt 4x0,25mm<sup>2</sup> PUR/PVC  
**44** ◀ = Cable 9Mt 4x0,25mm<sup>2</sup> PUR/PVC

**f** Cursor type  
**X** ◀ = none  
**0** ◀ = Magnetic cursor 18 x 8 mm - AW2011A anodized  
**1** ◀ = Magnetic cursor 18 x 10 mm - AW2011A anodized

**g** Customization  
**X** ◀ = None  
**?** ◀ = Customization code

**h** Approvals  
**1** ◀ = Standard components<sup>(3)</sup>

L.4 - DS0024 R02 MAG300 Analog - 06/11/24

(1) Not all combinations can be ordered. Please contact TSM for confirmation before placing an order.  
 (2) Standard component. It does not constitute a safety component as defined in the Machinery Directive 2006/42/CE.

# MAG300 Analog

## MAGNETOSTRICTIVE SENSOR

Absolute measuring length up to 2.5 m linear position transducer

### TECHNICAL SPECIFICATION

Measuring range	0.1...2.5 m
Magnetostrictive resolution	0.1 mm
Magnetostrictive linearity (Ta = 25°C)	up to 250mm <math>\pm 0.1\text{ mm}</math> from 250 to 2500mm $\pm 0.04\%$ FS
Magnetostrictive repeatability (Ta = 25°C)	$\pm 0.1\text{ mm}$
Operating pressure	According to EN 13480-5 350 bar (Peak: 500 bar)
Protection class	IP67 (IP69K with M12 plug system)
Temperature range	-40°C ... +85°C
Temperature coefficient	$\pm 0.004\%$ FS/°C
Housing	Head and rod: stainless steel AISI316
Rod diameter	10 mm
Shock resistance	acc. to EN 60068-2-27 30 G, 11 ms 100 Shocks per axis
Vibration resistance	acc. to EN 60068-2-6 10 ... 150 Hz

### ELECTRICAL CHARACTERISTICS

Power supply range	see order code
Startup time	200 ms
Inrush current	1.5A - 2ms @ 12VDC
Current consumption. (with load at FS)	<u>Current output:</u> 58 mA (12 VDC); 43 mA (24 VDC) <u>Voltage output:</u> 34 mA (12 VDC); 19 mA (24 VDC)
Load resistor	> 10 kOhm, voltage output type < 500 Ohm, current output type
Electromagnetic compatibility	acc. to EN 61000-6-2, EN 61000-6-4
EU conformity	EMC directive 2014/30/EU RoHS directive 2011/65/EU + 2015/863/EU

### OPERATING PRINCIPLE

The operating principle is based on the magnetostrictive effect. The application of periodic short current pulses in the magnetostrictive wire generates an induced magnetic field. The interaction of the magnetic cursor, connected to the moving object in the application, with this field generates a momentary torsional strain on the magnetostrictive wire which propagates along it as in a waveguide. When the ultrasonic wave reaches the end of the guide, it is detected by a sensitive element which converts it into an electrical signal. Since the velocity of propagation is known, the linear position is computed by measuring the time-of-flight of the pulse.



# MAG300 Analog

## MAGNETOSTRICTIVE SENSOR

Absolute measuring length up to 2.5 m linear position transducer



### ELECTRICAL CONNECTIONS

#### PLUG SYSTEM M12 X 4 PINS

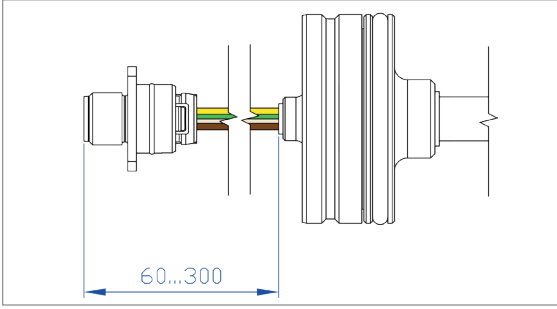

FRONT VIEW

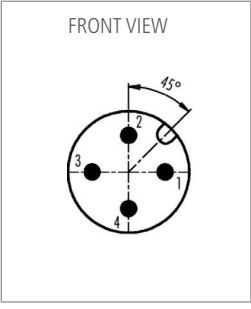

PIN	COLOR	SIGNAL
1	Ye	+Vin
2	Bn*	n.c.*
3	Wh	GND
4	Gn	V / I out



\* = PIN MARKED n.c. MUST NOT BE CONNECTED  
Applying a voltage to this pin can damage the device!

#### CABLES

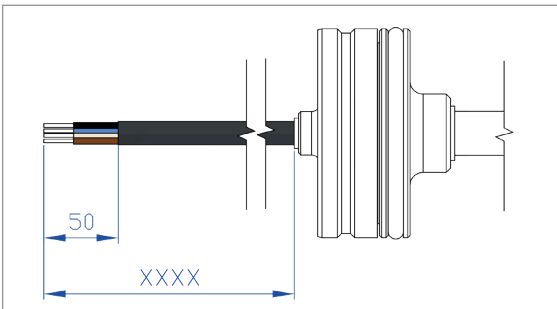

FRONT VIEW

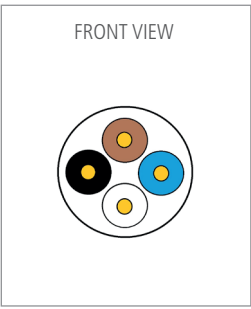

COLOR	SIGNAL
Brown	+Vin
White*	n.c.*
Blue	GND
Black	V / I out



\* = PIN MARKED n.c. MUST NOT BE CONNECTED  
Applying a voltage to this pin can damage the device!

# MAG300 Analog

## MAGNETOSTRICTIVE SENSOR

Absolute measuring length up to 2.5 m linear position transducer

### CURSOR TYPES

#### 1] Magnetic cursor 18 x 10 mm - AW2011 anodized

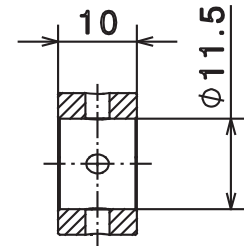
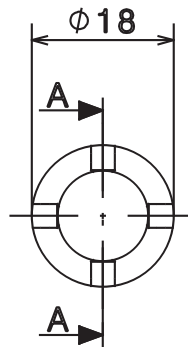
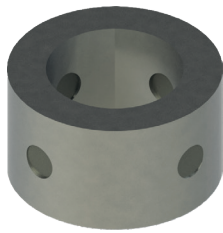

Section A-A

#### 2] Magnetic cursor 18 x 8 mm - AW2011 anodized

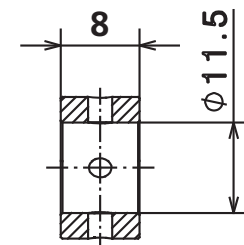
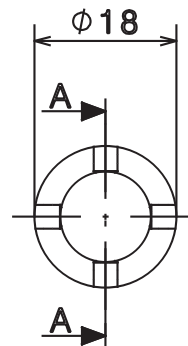
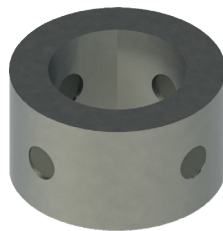

Section A-A

# MAG300 Analog

## MAGNETOSTRICTIVE SENSOR

Absolute measuring length up to 2.5 m linear position transducer



### DIMENSIONS [mm]

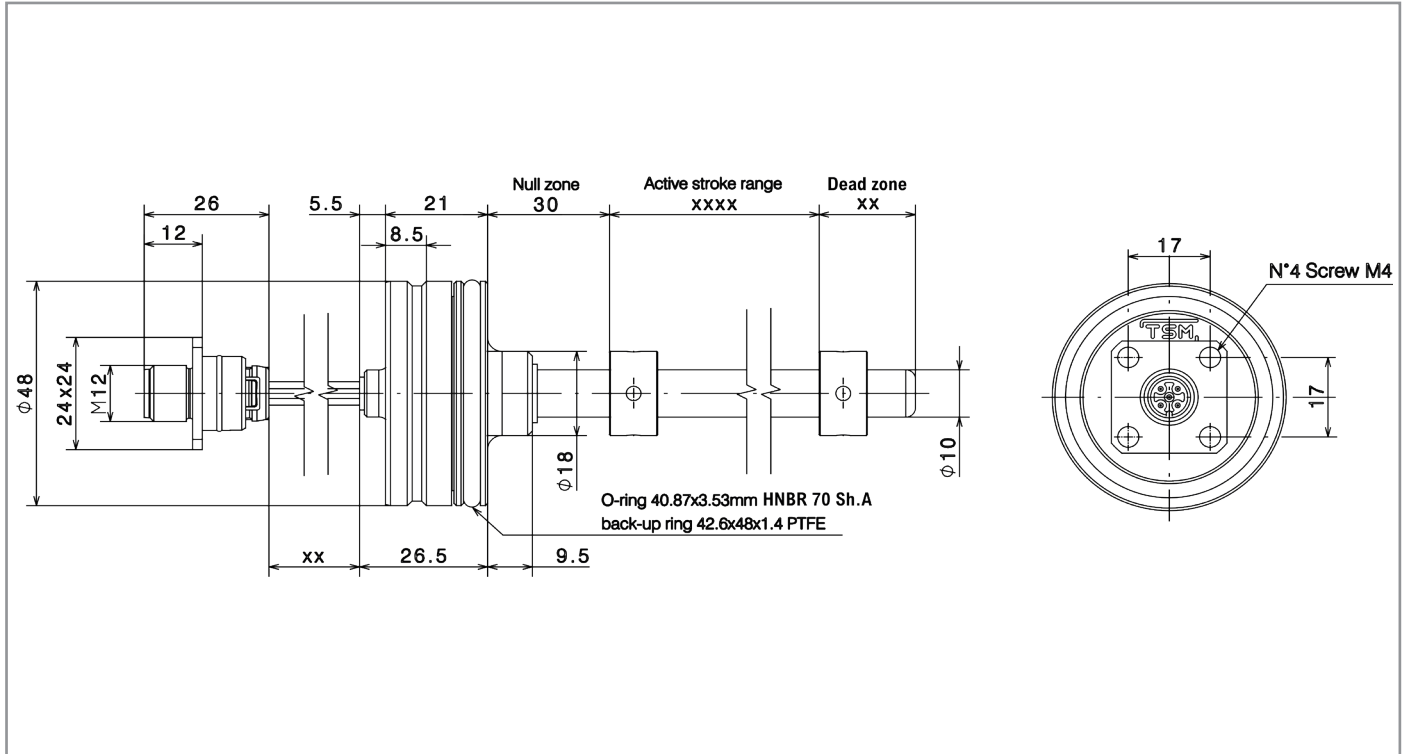

L.4 - DS0024 R02 MAG300 Analog - 06/11/24

# MAG300 Analog

## MAGNETOSTRICTIVE SENSOR

Absolute measuring length up to 2.5 m linear position transducer

### Head seat

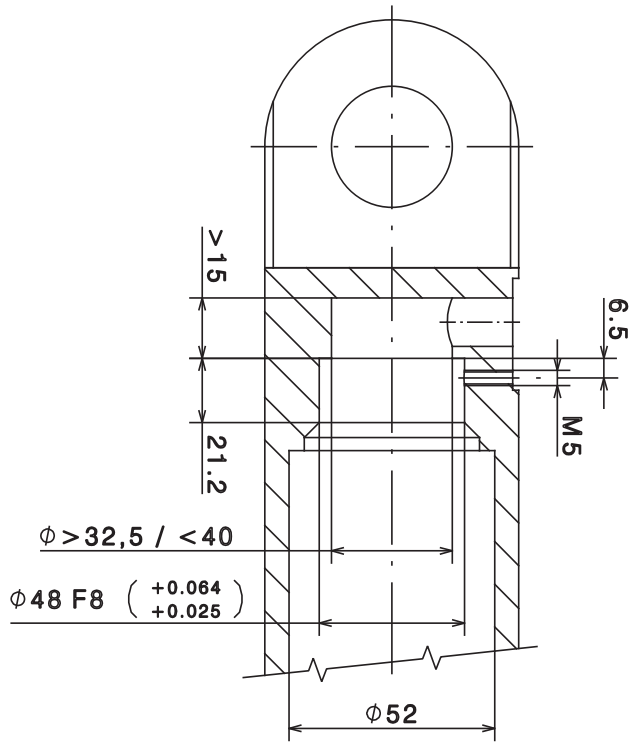

### Head fixing

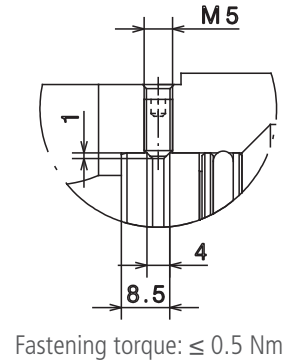

### Magnet seat

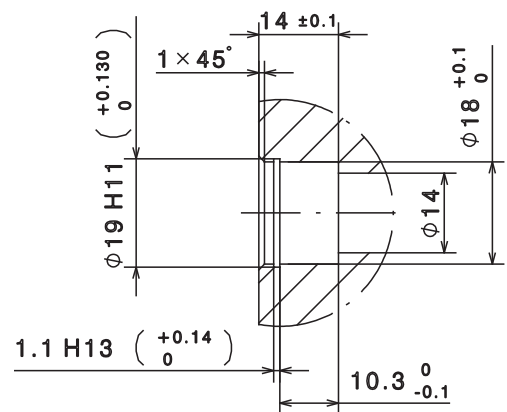

### M12x1 connector seat

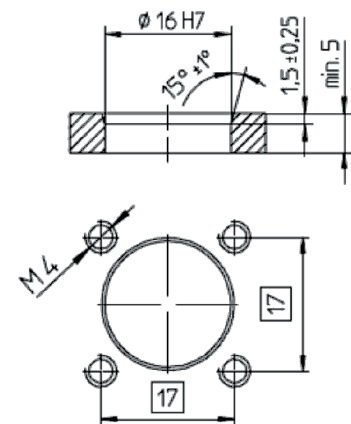



# MAG300 Analog

## MAGNETOSTRICTIVE SENSOR

Absolute measuring length up to 2.5 m linear position transducer

### OPERATING MANUAL

#### Safety and operating instructions

Before handling, installing or using the MAG300 sensor, please read this documentation carefully and follow the safety instructions.

The information provided in this technical guide is intended ONLY for qualified personnel or suitably trained service technicians who are familiar with the concepts illustrated below and are accustomed to reading and understanding the symbols typically used in the mechanical technical drawing.

#### Intended use

MAG300 sensors are designed to be used on hydraulic devices installed on mobile machines or vehicles with battery power (12VDC or 24 VDC).

MAG300 are designed and built in compliance with current electrical engineering standards and are made to the state of the art. They meet the EMC requirements for interference emission and immunity for mobile machines and vehicles. However, their use may endanger the user or third parties or cause damage to the sensor and other equipment. The sensors are devices intended for measuring's tasks in the field of mobile hydraulics; for this reason, are considered accessories and must be connected to suitable evaluation electronics, such as a PLC, IPC, indicator or other type of electronic control unit.

To ensure perfect and safe operation of the sensor, maximum care during transport, storage, assembly and commissioning is mandatory. To maintain this condition, the installation, connection and service work can only be performed by qualified and authorized personnel.

#### Information related to danger

Information related to danger is intended for your personal safety and for the safety of the described product or connected equipment against damage.

#### Installation and operation

If a failure or functional disorder of the sensors can cause danger to people or imply an hazard of damage to the operating facilities, additional safety measures are mandatory to prevent it.

In the event of trouble, turn off the sensor and protect it from unauthorized operation.

To maintain the sensor operability, it is indispensable to observe the following information:

- Protect the sensor against mechanical damage during installation and operation.
- Lubricate O-ring and backup ring before mounting in the cylinder.

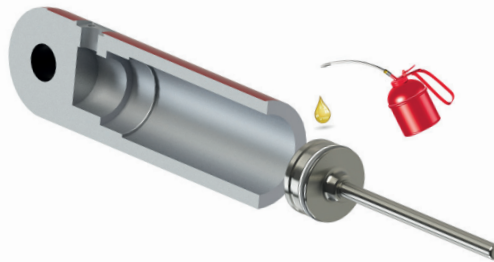

- The clearance fit of the sensor and the cylinder does not require the application of an excessive forces or the use of special tools or special aids. The operator simply needs to exert a minimum pressure, sufficient to overcome the friction of the O-ring and backup ring seals.

- Push the sensor into the seat carefully. Make sure that conductors or cables are not under strain.
- If required, use an individually prepared bush (e.g., polyamide) to press the sensor into the seat



# MAG300 Analog

## MAGNETOSTRICTIVE SENSOR

Absolute measuring length up to 2.5 m linear position transducer



-Never use a steel hammer! Do not subject the sensor and the tools to hard strokes during installation! If necessary, use only a rubber mallet to hammer the sensor in position carefully



- Do not open or disassemble the sensor.
- Connect the sensor carefully; check the polarity of the power connections; do not invert the power cables with the signal cables; do not power the sensor with a voltage outside the allowed limits
- Do not remove the antistatic cover until the sensor needs to be connected to the system. If the sensor is disconnected, put the cover back until reinstallation.

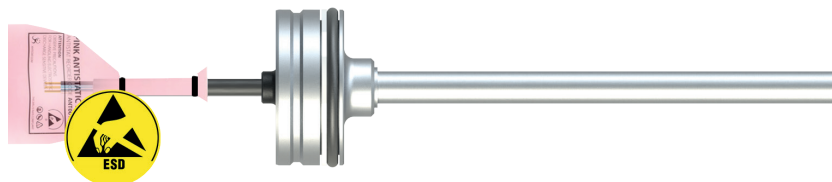

- Do not use the sensor outside the operating temperature range.
- Always check the correct operating of the sensor before starting the machine and carrying out any maneuvers
- Check and document the function of the position sensor regularly
- In event of malfunction do not try to repair the sensor. Repairs can only be performed by TSM or by personnel authorized by TSM.
- Do not separate the magnetic cursor from the sensor. For correct operation, each sensor must be mounted in the cylinder with its own supplied cursor.
- During installation, make sure that cables are located correctly inside the cylinder.
- The cables must not be squeezed and should be laid without mechanical stress.



**PIN MARKED n.c. MUST NOT BE CONNECTED**

L.4 - DS0024 R02 MAG300 Analog - 06/11/24