

LENS GASKETS

The proven high-pressure gaskets

Lens gaskets are reusable, as the sealing effect is generally achieved by elastic deformation of the surfaces.

The projected sealing width b_G is calculated in relation to the angle α , which forms the sealing surface against the direction of the force (tubular axis) depending on the E modulus E_G and the surface pressure exerted by

$$b_G = 100 \sigma / E_G \cdot r \cdot \sin \alpha.$$

We can also specially produce bellows lenses, lens blind spectacle gaskets and half-lenses.

Lens blind spectacle gaskets are made of a sealing lens and a lens blind, which are connected by a ligament. It is also usual to use lens blinds on their own. In this case, it is useful to weld on a small plate to render the lens blind distinguishable.

Gasket profiles

Profile	Cross-section
A5	
A5S	
A5BS	

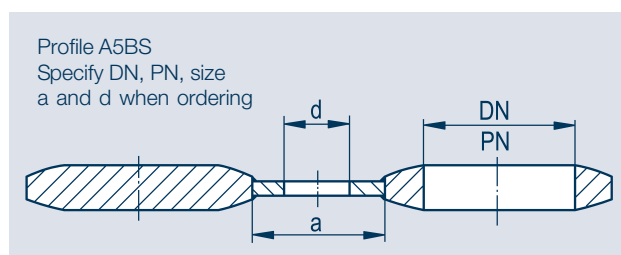

Lens gaskets are impervious to overpressure. With increasing loads, the contact surface between the spherical lens surface and the spherical flange groove increases, so that the surface pressure only increases to a lesser extent.

A disadvantage with standard sealing lenses is that, at high pressures and temperatures, the sealing lens can bulge along the circumference and weaken the tension of the connection. Also, at greater nominal diameter, the flange can become stuck in the area of the raised face diameter d_5 and lift up at the sealing diameter.

Steel type designation	Material number	For circulatory temperatures in °C	Code designation on the outer edge
S235JRG2	1.0038	to 425	none
P265GH	1.0425	to 425	none
16Mo3	1.5415	425 to 475	1 Punch mark
13CrMo4-5	1.7335	425 to 520	2 Punch marks
10CrMo9-10	1.7380	520 to 580	3 Punch marks
X6CrNiTi18-10	1.4541	350 to 550	4 Punch marks
12CrMo19-5	1.7362	max. 650	1 Notch
X6CrNiMoTi17-12-2	1.4571	max. 550	3 Notches

Further technical data see section "Materials commonly used".

Gasket limiting values

Profile	Materials	A5, A5S, A5BS									
		Iron 1.1003	Heat-resistant mild steel 1.5415	Heat-resistant mild steel 1.7362	Stainless steel 1.4541	Stainless steel 1.4828	Steel St 35 copper-plated	Steel 1.4541 silver-plated	Copper 2.0090	Monel 2.4360	
Recommended max. roughness of the flange surfaces	μm from to	3,2 6,3	3,2 6,3	3,2 6,3	1,6 3,2	1,6 3,2	3,2 6,3	6,3 12,5	3,2 6,3	3,2 6,3	
Surface pressure limits for 20 °C	N/mm^2 σ_v σ_s	235 525	300 675	400 900	335 750	400 900	135 600	100 750	135 300	260 660	
E-Modul at 20 °C	kN/mm^2	210	210	210	200	200	210	200	128	178	
Surface pressure limits for 300 °C	N/mm^2 σ_v σ_s	235 315	300 585	400 730	335 630	400 750	135 390	100 630	135 150	260 650	
E-Modul at 300 °C	kN/mm^2	185	185	190	186	186	185	186	114	175	

LENS GASKETS

The proven high-pressure gaskets

Lens gaskets for flange connections PN 63 to PN 400

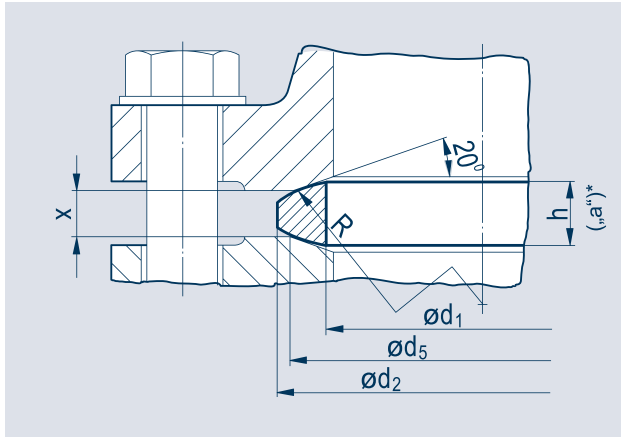

Conforms to DIN 2696 : 1999-08*

Ordering example for a lens gasket, DN 100, PN 63, conforming to DIN 2696, made of ...¹⁾:

Lens gasket, DN 100, PN 63, DIN 2696 Series 1 / 1.7335 DIN

DIN 2696 : 1999-08, Series 2

DN	d ₁	d ₂	d ₅	h	r	x
PN 63						
50	52	78	68	14,6	87	9
100	100	143	127	24,5	166	15
125	124	180	157	33,6	205	22
150	148	210	183	38,4	242	26
PN 100						
10	11	21	18	8,4	21	6
15	16	28	27	9,7	31	6
25	25	43	39	10,8	47	6
40	39	62	55	13,6	68	8
50	51	78	68	14,9	87	9
100	98	143	127	25,2	164	15
125	121	180	157	34,6	203	22
150	145	210	183	39,4	240	26
PN 160						
10	10	21	18	8,7	20	6
15	16	28	27	9,7	31	6
25	25	43	39	10,8	46	6
40	38	62	55	13,9	67	8
50	49	78	68	15,6	86	9
100	92	143	127	27,2	160	15
125	113	180	157	37,3	197	22
150	134	210	183	43,1	232	26
PN 250						
15	15	28	27	10,0	31	6
25	23	43	39	11,4	45	6
40	35	62	55	14,9	65	8
50	45	78	68	16,9	82	9
PN 320						
10	9	21	18	9,0	20	6
15	14	28	27	10,3	30	6
25	20	43	39	12,3	43	6
40	32	62	55	15,7	64	8
100	101	143	127	24,2	167	15
125	119	180	157	35,3	202	22

Dimensions in mm

1) Specify material when placing order

* Sealing lenses with dimensions conforming to with DIN 2696 April 1972 edition must always be arranged in advance. To avoid misunderstandings the desired sealing lens height "a" should always be given for the internal diameter d₁ specified.

DIN 2696 : 1999-08, Series 1

DN	d ₁	d ₂	d ₅	h	r	x
PN 63						
50	55	78	68	13,6	90	9
65	70	102	85	18,3	113	13
80	82	116	97	18,3	131	13
100	107	143	127	22,1	171	15
125	131	180	157	31,2	210	22
150	158	210	183	34,9	249	26
200	205	276	243	40,5	327	27
PN 100						
10	14	21	18	7,4	23	6
15	18	28	27	9,1	32	6
25	29	43	39	9,5	49	6
40	43	62	55	12,2	71	8
50	54	78	68	13,9	89	9
65	69	102	85	18,7	112	13
80	81	116	97	18,7	130	13
100	105	143	127	22,8	169	15
125	128	180	157	32,3	208	22
150	155	210	183	36,0	146	26
200	200	276	243	42,2	323	27
PN 160						
10	14	21	18	7,4	23	6
15	18	28	27	9,1	32	6
25	28	43	39	9,8	49	6
40	42	62	55	12,6	70	8
50	53	78	68	14,3	88	9
65	67	102	85	19,4	110	13
80	77	116	97	20,1	127	13
100	99	143	127	24,8	165	15
125	120	180	157	35,0	202	22
150	144	210	183	39,7	239	26
175	166	243	218	39,2	280	21
200	188	276	243	44,3	314	25
PN 250						
15	17	28	27	9,4	32	6
25	27	43	39	10,2	48	6
40	39	62	55	13,6	68	8
50	48	78	68	15,9	85	9
65	61	102	85	21,4	106	13
80	80	116	97	19,0	129	13
100	99	143	127	24,8	165	15
125	121	180	157	34,6	203	22
150	143	210	183	40,1	238	26
200	195	276	243	41,9	320	25
PN 320						
10	12	21	18	8,1	22	6
15	15	28	27	10,0	31	6
25	24	43	39	11,1	46	6
40	36	62	55	14,5	66	8
50	48	78	68	16,0	84	9
65	67	102	85	19,3	111	13
80	77	116	97	20,1	127	13
125	129	180	157	31,9	209	22
150	144	210	183	39,7	239	26
175	164	243	218	39,9	279	21
200	185	276	243	45,3	312	25
PN 400						
10	10	21	18	8,7	20	6
15	17	28	27	9,4	32	6
25	29	43	39	9,5	49	6
40	41	62	55	12,9	70	8
50	52	78	68	14,6	87	9
65	70	102	85	18,3	113	13
80	80	116	97	19,0	129	13
100	96	143	127	25,9	162	15
125	134	180	157	30,2	212	22
150	150	210	183	37,7	243	26
200	193	276	243	42,6	319	25

Dimensions in mm

LENS GASKETS

The proven high-pressure gaskets

Lens gaskets for flange connections PN 63 to PN 400

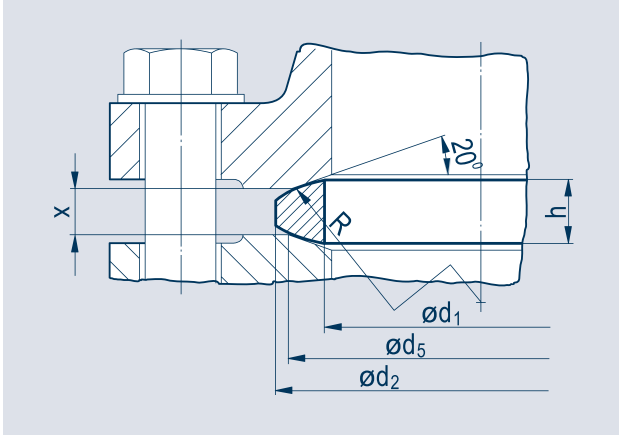

Works standard 108²⁾

Ordering example for a lens gasket with $d_1 = 94$ mm internal diameter and $d_2 = 143$ mm external diameter, made of ...¹⁾:

Lens gasket 94 x 143 WN 108 / 1.7335

Works standard 108

DN	$d_{1, \min}^*$	h_{\max}	$d_{1, \max}^*$	h_{\min}	d_2^*	r^*	d_5^*	x^*
PN 63 to PN 400								
10	10	8,0	14	7,0	21	25	18	5,7
15	14	10,0	18	9,0	28	32	27	6,0
25	20	11,5	29	9,5	43	50	39	6,0
40	34	15,0	43	12,5	62	70	55	8,0
50	46	16,5	55	13,5	78	88	68	9,0
65	62	21,0	70	18,5	102	112	85	13,0
80	72	21,5	82	18,5	116	129	97	13,0
100	94	26,0	108	22,0	143	170	127	15,0
125	116	35,5	135	29,5	180	218	157	22,0
150	139	41,0	158	35,0	210	250	183	26,0
PN 63 to PN 100								
(175)	176	42,5	183	40,5	243	296	218	28,0
200	198	42,5	206	40,0	276	329	243	27,0
250	246	43,0	257	39,5	332	406	298	25,0
300	295	43,5	305	40,5	385	473	345	26,0
350	330	45,5	348	39,5	425	538	394	23,0
400	385	45,5	395	42,0	475	610	445	24,0
PN 160 to PN 400								
(175)	162	40,0	177	35,5	243	296	218	21,0
200	183	45,5	200	40,0	276	329	243	25,0
250	230	48,0	246	43,0	332	406	298	25,0
300	278	53,0	285	51,0	385	473	345	30,0

Dimensions in mm

¹⁾ Specify material when placing order.

²⁾ Unless otherwise agreed, the sealing lenses will be supplied with $d_{1, \min}$ and h_{\max} . The interior diameters should be adapted to the by boring of the integral or collar flanges.

* In accordance with DIN 2696 April 1972.