

S-TYPE STAINLESS STEEL LOAD CELL FOR COMMERCIAL WEIGHING

capacities 250kg - 7500kg

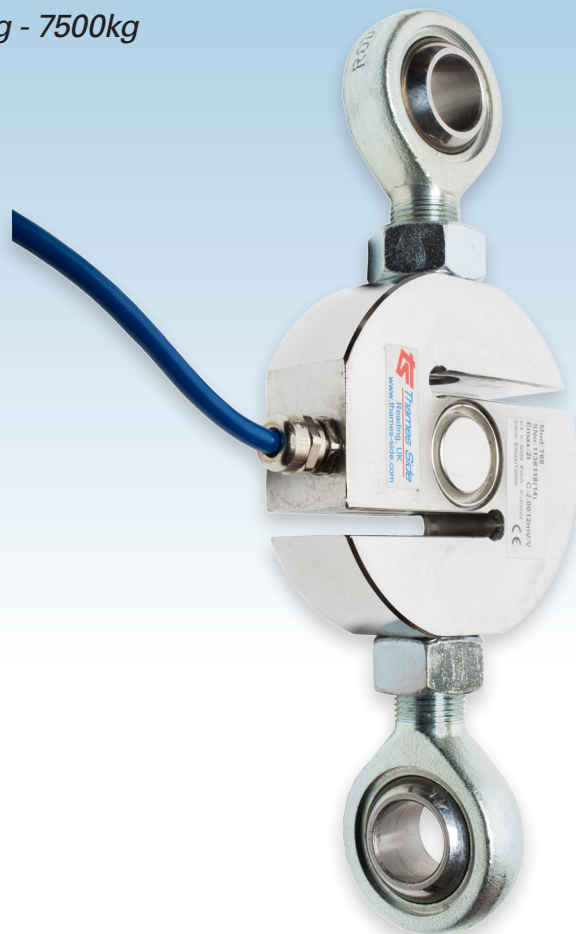

Upper and lower rod end bearings are optional items

The T68 stainless steel S-type load cell is ideal for 'commercial' weighing, due to its approval to OIML R60 3000 divisions (C3). Its fully welded and hermetically sealed construction ensures total environmental protection to IP68 / IP69K, coupled with excellent long term signal stability and performance. Additionally, it is supplied with a high durability Polyurethane cable and the option of rod end bearings, making it the benchmark S-type load cell.

An optional high temperature variant for continuous operation in environments up to 150 °C is also available. For applications in aggressive environments where stress corrosion or acid attack is a potential problem, a special Parylene coating can be specified as an option

- Stainless steel load sensor
- 2 mV/V rationalised output
- Fully welded and hermetically sealed to IP68 / IP69K
- 5 year warranty
- Suitable for use in tension, compression or a bi-directional manner
- Optional rod end bearings available
- Excellent long term stability
- Approved to 3000 divisions (C3) OIML R60 Class C
- High durability Polyurethane cable

T68

technical specification...

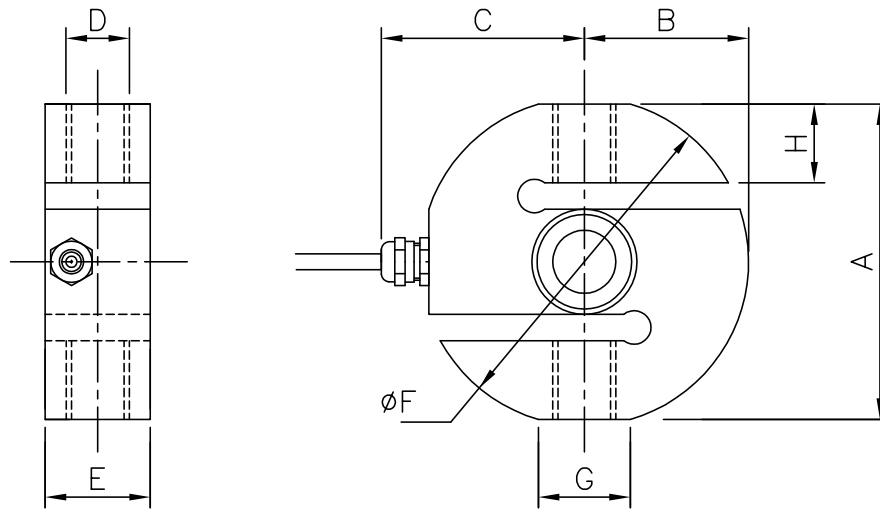

T68 Load Cell

	Load cell specification	Units
Load Cell Capacities (E_{max})	250, 500, 1000, 2000, 5000, 7500	kg
Rated Output	2.0	mV/V \pm 0.1%
Accuracy Class	3000**	n.OIML
Combined Error	$< \pm 0.017$	%*
Non-repeatability	$< \pm 0.015$	%*
Creep - 30mins at 20°C	$< \pm 0.016$	%*
Temperature Effect on Zero Balance	$< \pm 0.002$	%* / °C
Temperature Effect on Span	$< \pm 0.0012$	%* / °C
Compensated Temperature Range	-10 to +55	°C
Operating Temperature Range	-40 to +95	°C
Safe Service Load	150	% E_{max} *
Ultimate Load	200	% E_{max} *
Zero Balance	$< \pm 2.0$	%*
Input Resistance	400	$\Omega \pm 20$
Output Resistance	350	$\Omega \pm 3$
Insulation Resistance	> 5000	M Ω @100V
Recommended Supply Voltage	5-15	V
Maximum Supply Voltage	15	V
Environmental Protection	IP68 / IP69K	
Cable Length	5	m
Cable Material	Polyurethane	
Nominal Shipping Weight	250, 500kg	1 kg
	1000, 2000kg	2 kg
	5000kg	4 kg
	7500kg	5.5 kg

* All percentages are related to Rated Output

** For capacity range 500 - 5000kg

Dimensions

Capacity (kg)	250-500	1000-2000	5000	7500
A	70	95	120	120
B	37.5	50	62.5	62.5
øC	50	60	72.5	72.5
D	M12	M20	M24	M24
	x 1.75P	x 1.5P	x 2P	x 2P
E	24.5	30	40	56
øF	75	100	125	125
G	26.9	31.2	35	35
H	15	26	30	30

All dimensions are in mm

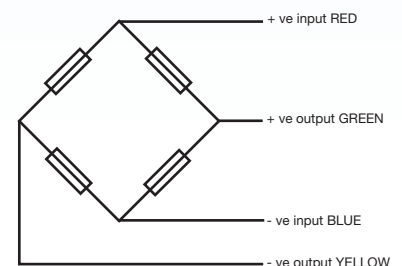

Electrical Connections

Via 4 wire, 5.7mm diameter, screened polyurethane cable.

Screen not connected electrically to load cell.

DISTRIBUTED BY:



THAMES SIDE SENSORS LTD

Unit 10, io Trade Centre, Deacon Way, Reading, Berkshire RG30 6AZ

tel: +44 (0) 118 941 1387

fax: +44 (0) 118 941 2004

sales@thames-side.co.uk

www.thames-side.com



Issue: T68.10.16

Our policy is one of continuous product enhancement. We therefore reserve the right to incorporate technical modifications without prior notification.

