

MasterMount®

Unique, patented load cell assembly for silo, tank and vessel weighing

capacities 2t to 30t

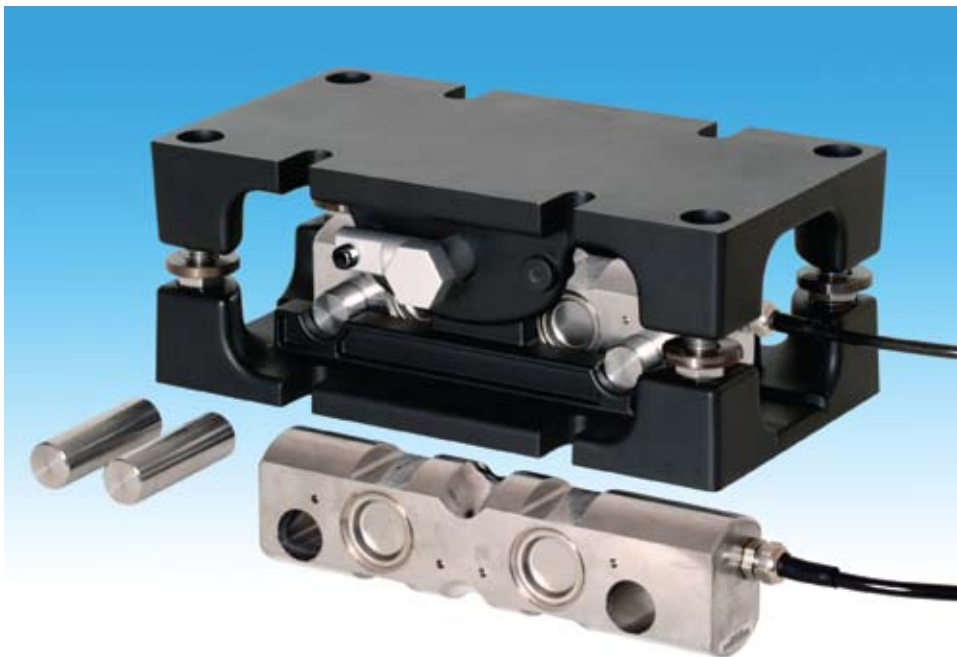

Load cell installation/removal under load without jacks or dummies

Stainless steel load cell, also available in ATEX approved and high temperature versions

Major savings on installation time and cost

5 year warranty

Substantial lift off prevention

Fully welded load cell construction to IP68

Allows vessel expansion and contraction

Resistant to off-axis loading

Low profile, stable design

Tough and durable paint finish

Vessel weighing problems solved simply and cost effectively. The MasterMount® is the latest addition to an innovative range of patented weighing assemblies which are designed with safety and ease of installation in mind.

MasterMount® - Innovation from Thames Side Sensors Ltd

Thames Side's **MasterMount®** is the latest in a range of unique patented load cell and mount combinations which include the **LeverMount®** and **LeverMount Lite®** and extends the range of capacities up to 30 tonnes.

The **MasterMount®** has primarily been designed for easy, safe, simple installation and removal of the load cell without the aid of specialist tools, jacks or other equipment.

The special design also avoids the need to use dummy cells whilst any welding or other work is being undertaken on the vessel. The high specification double ended stainless steel shear beam load cell incorporated in the **MasterMount®** is the same model used in Thames Side's popular VC3500 'traditional' mount arrangement. The load cell can also be specified with ATEX EEx ia IIC T6 certification for both dust and gas in all zones as well as Ex nA II T6 gas only certification which allows Zone 2 use without safety barriers.



High temperature versions are also available for operation up to 150°C utilising special high temperature components and PTFE Teflon cable. Although the standard load cell is manufactured from stainless steel and sealed to IP68, special parylene coating of the load cell is available as an option to provide additional protection in extreme environments where stress corrosion could occur.

A patented lever and cam mechanism enables the top plate of the loading assembly to be raised and lowered with a 180 degree turn, which can be accomplished easily, with just an M30 socket spanner and T-bar. The stainless steel load cell is retained within the assembly by simple captivated pins, thus avoiding the use of fiddly retaining clips. Lift off protection is provided through the mount itself, rather than the traditional design of under or through the load cell, which protects the load cell from reverse shock loading. The Mastermount® assembly is manufactured from high strength cast steel and is protected by a durable and hard wearing corrosion resistant paint finish.

Once the **MasterMount®** loading assembly has been fitted under the vessel, installation and removal of the load cell can be accomplished in minutes, resulting in large savings in installation costs.

The **MasterMount®** is just one product in an extensive range of innovative Thames Side load cell and mount arrangements with capacities from 10kg up to 600 tonnes designed specifically for Process Weighing and Materials Storage applications.

Our Technical Department is happy to provide free technical and applications advice as well as help with optimum load cell selection.

MasterMount® - Innovation from Thames Side Sensors Ltd

FEATURES

- Purpose designed cast alloy steel mount and stainless steel load cell
- Simple, robust two part casting supplied locked in position via transit bolts
- Stainless steel, IP68, fully welded double ended shear beam load cell
- Special cam design loading shaft raises and lowers the top plate and vessel
- Vessel can be raised and lowered under load
- No jacking screws or support pillars
- Substantial anti-lift facility through mount, not load cell
- Minimal difference between the raised and lowered height of 3 mm
- One design covers the range from 2,000kg to 30,000kg
- Load cell can be safely installed or removed under loaded vessel

BENEFITS

- Ideal for process weighing applications that require an accurate, safe and cost effective solution
- Aesthetically pleasing design
- Suitable for use in the harshest of industrial environments
- No need for alternative lifting devices such as pad jacks
- Easier, quicker and safer than alternative mount arrangements
- No stripped threads or top plate interference
- Increased safety, eliminating potential damage to the load cell
- Reduces the need to compensate for pipe work without flexible connections
- Covers the majority of process weighing applications
- Much less down time and reduced cost when compared to conventional mounts

INSTALLATION DETAILS

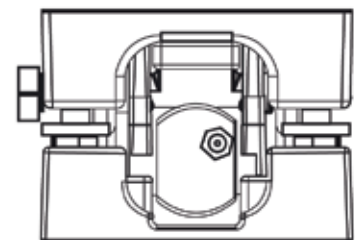
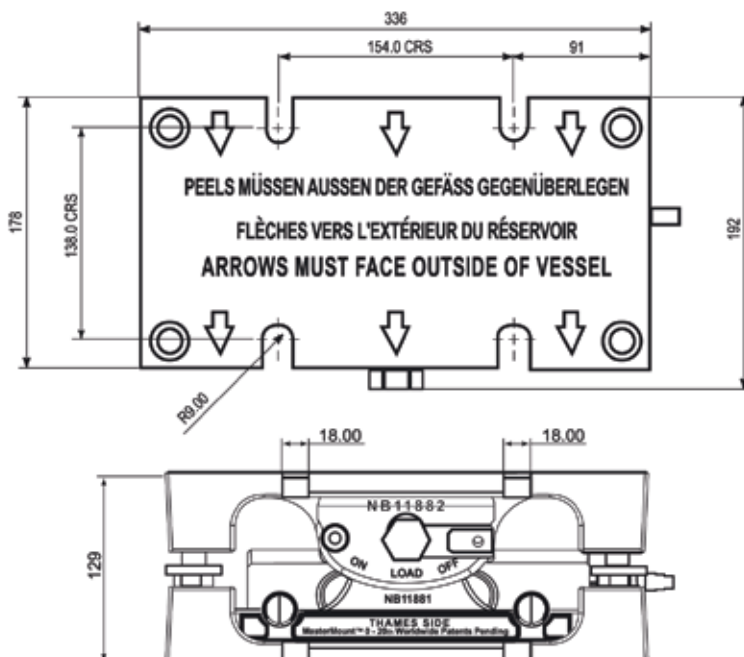

MasterMount® - Innovation from Thames Side-Sensors Ltd

		Units
Standard Load Ranges	2,5,10,15,20,30	t
Full Load Output	2.0(+/- 0.25%)	mV/V
Excitation Recommended	10	V
Excitation Maximum	18	V
Safe Service Load	150	%
Ultimate Load	300	%
Maximum Lift Off	30	%
Combined Error	<+/- 0.03	%
Repeatability	<+/- 0.015	%
Output at Zero Load	<+/- 2.0	%
Input Resistance	785 +/- 20	ohms
Output Resistance	700 +/- 5	ohms
Operational Temperature Range	-50 to +80	C
Compensated Temperature Range	-10 to +40	C
Temperature Coefficient on Zero	<+/- 0.002	%/C
Temperature Coefficient on Span	<+/- 0.0012	%/C
Environmental Protection	IP68	
Insulation	>500 at 100Vdc	M ohms

All percentages are related to Full Rated Load

Construction

Mounting assembly

Alloy steel, durable painted finish

Shafts

Corrosion resisting hardened stainless steel

Electrical Connections

4 Core 16 / 0.2 mm, screened polyurethane cable.

Cable length 20m

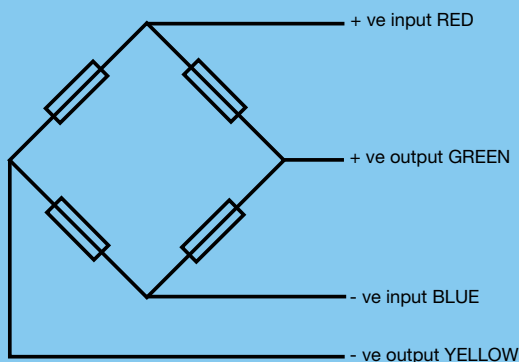

Screen not connected to Load Cell body.

In the interests of continued product development, Thames Side Sensors Ltd reserves the right to alter product specifications without prior notice.

MasterMount® is a registered trade mark of Thames Side Sensors Limited.

Distributed by



Thames Side Sensors Ltd

Unit 10, io Trade Centre, Deacon Way,

Reading, Berkshire RG30 6AZ

tel: +44 (0) 118 941 1387 fax: +44 (0) 118 941 2004

e-mail: sales@thames-side.co.uk

web: www.thames-side.com