

RE36 series rotary encoders



The RE36 is a high-speed rotary magnetic encoder designed for use in harsh environments. The traditional design enables easy integration on existing machines.

A magnet is mounted to the shaft within the encoder's body. Rotation of this magnet is sensed by a custom encoder chip within the body, and processed to give the required output format.

The encoder chip processes the signals received to provide resolutions to 13 bit (8,192 positions per revolution) with high operational speeds. Resolution options include binary and decimal. Output signals are provided in industry standard absolute, incremental or analogue formats.

The compact encoder body is 36 mm in diameter and provides dirt immunity up to IP68.

The RE36 can be used in a wide range of applications including marine, medical, print, converting, industrial automation, metal working and instrumentation.

5 V power supply version

RE36I- incremental with 80 to 2,048 pulses per revolution (320 to 8,192 counts per revolution with x 4 evaluation)

RE36S-synchro serial interface (SSI) and incremental, RS422

24 V power supply version

RE36P-absolute parallel interface with 512 positions per revolution

RE36I-incremental with 80 to 2,048 pulses per revolution (320 to 8,192 counts per revolution with x 4 evaluation)

RE36V-linear voltage output in a range of variants

RE36C-linear current output in a range of variants

System features:

- Excellent immunity to IP68
- High speed operation to 20,000 rpm
- 36 mm diameter body
- Industry standard absolute, incremental and linear output formats
- Binary and decimal resolution options
- Accuracy to $\pm 0.3^\circ$
- Simple integration
- Low inertia

RE36 installation drawing

Dimensions and tolerances in mm

IP64/68

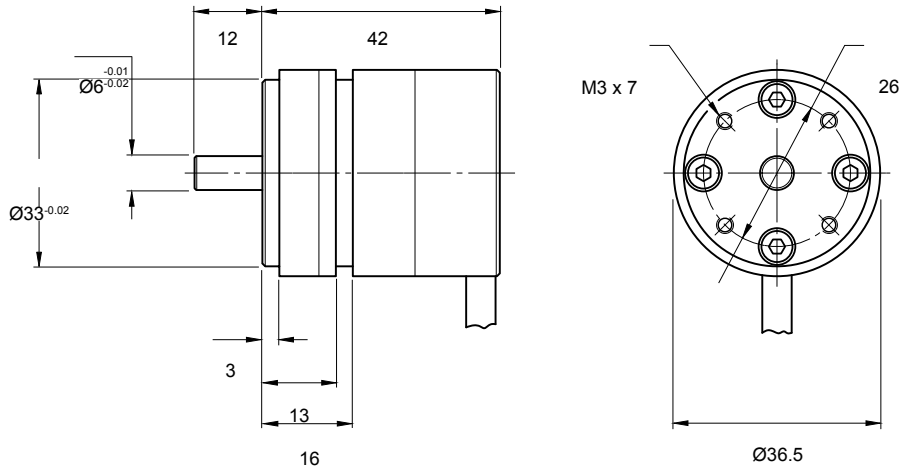

IP53

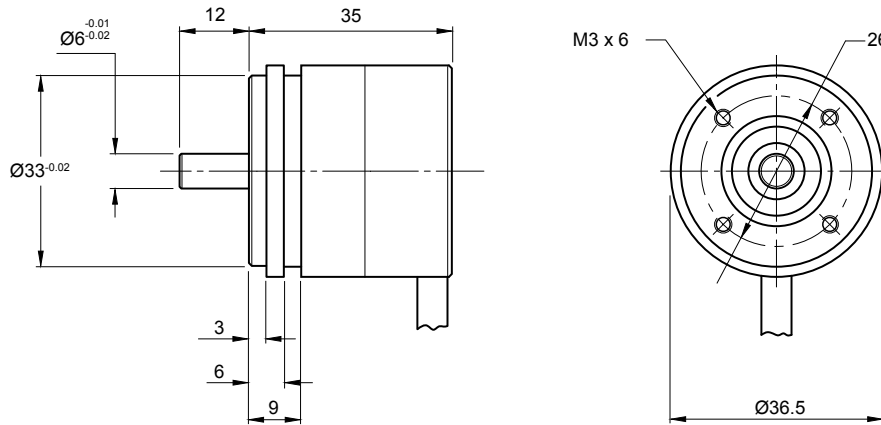

Table of expected bearing life ratings in hours

Speed (rpm)	Rad. load 15 N	Rad. load 20 N	Rad. load 25 N	Rad. load 30 N
500	296,282	227,542	178,523	142,631
1,000	148,142	113,767	89,267	71,317
2,000	74,071	56,883	44,633	35,658
5,000	29,628	22,753	17,853	14,263
10,000	14,814	11,377	8,927	7,131
15,000	9,876	7,584	5,951	4,754
20,000	7,407	5,688	4,463	3,566

Maximum recommended shaft loads:
radial 30N, axial 15N

Operating and electrical specifications

Humidity (for IP64 version)	Storage 95% maximum relative humidity (non-condensing) (IEC 61010-1) Operating 80% maximum relative humidity (non-condensing) (IEC 61010-1)
Acceleration	Operating 500 m/s ² BS EN 60068-2-7:1993 (IEC 68-2-7:1983)
Shock (non-operating)	1000 m/s ² , 6 ms, 1/2 sine BS EN 60068-2-27:1993 (IEC 68-2-27:1987)
Vibration (operating)	100 m/s ² max at 55 to 2000 Hz BS EN 60068-2-6:1996 (IEC 68-2-6:1995)
EMC compliance	BS EN 61326
Cable	Outside diameter 5 mm
Mass	Encoder unit 1 m cable (no connector) IP53 side cable 105 g, IP64/IP68 side cable 128 g
Environmental sealing	IP53
NOTE:	IP64 (IP68 optional) BS EN 60529 IP68 version must be operated immersed in fluid to maintain bearing/seal life

Output specifications - 5 V supply

RE36I – Incremental outputs

Square wave differential line driver to RS422

Power supply	$V_{dd} = 5 V \pm 5\%$
Power consumption	23 mA for 9 bit resolution 35 mA for all other resolutions
Output signals	A, B, Z, A-, B-, Z- (RS422)
Max. cable length	50 m
Connector options	9 pin 'D' type plug (standard) Flying lead
Temperature	Operating -25 °C to +85 °C Storage -40 °C to +125 °C

Resolution options (counts per revolution)	Maximum speed (rpm)	Accuracy*	Hysteresis
320, 400, 500	20,000	$\pm 0.5^\circ$	0.18°
512	20,000	$\pm 0.5^\circ$	0.45°
800, 1,000, 1,024	20,000	$\pm 0.3^\circ$	0.18°
1,600, 2,000, 2,048	10,000	$\pm 0.3^\circ$	0.18°
4,096	5,000	$\pm 0.3^\circ$	0.18°
8,192	2,500	$\pm 0.3^\circ$	0.18°

* Worst case within operational parameters including magnet position and temperature.

Timing diagram

(complementary signals not shown)

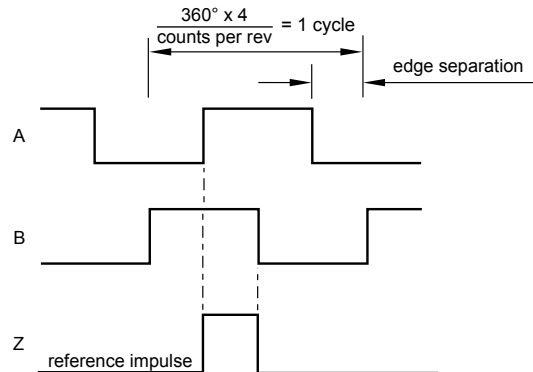

Recommended signal termination

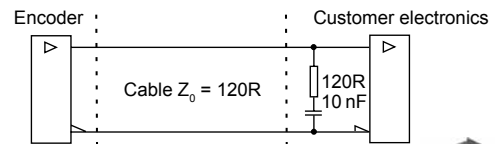

B leads A for clockwise rotation of shaft



RE36S – Absolute binary synchro-serial interface (SSI)

Serial encoded absolute position measurement

Output code	Natural binary
Power supply	$V_{dd} = 5 V \pm 5\%$
Power consumption	23 mA for 9 bit resolution 35 mA for all other resolutions
Repeatability	$\leq 0.07^\circ$
Data output	Serial data (RS422)
Data input	Clock (RS422)
Max. cable length	100 m (at 1 MHz)
Connector options	9 pin 'D' type plug (standard) Flying lead
Temperature	Operating -25 °C to +85 °C Storage -25 °C to +125 °C

Resolution options (positions per revolution)	Maximum speed (rpm)	Accuracy*	Hysteresis
320, 400, 500, 512	20,000	$\pm 0.5^\circ$	0.18°
800, 1,000, 1,024	20,000	$\pm 0.3^\circ$	0.18°
1,600, 2,000, 2,048	10,000	$\pm 0.3^\circ$	0.18°
4,096	5,000	$\pm 0.3^\circ$	0.18°
8,192	2,500	$\pm 0.3^\circ$	0.18°

* Worst case within operational parameters including magnet position and temperature.

Timing diagram

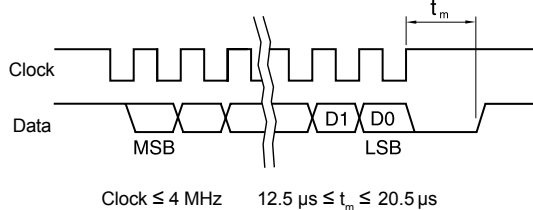

Recommended signal termination

(For data output lines only)

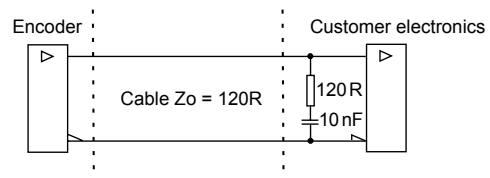

Position increases for clockwise rotation of shaft



Output specifications - 24 V supply

RE36P – Absolute binary parallel interface

Parallel absolute position measurement

Output code	Natural binary
Power supply	8 V to 26 V = V_{supply}
Power consumption	(at 24 V) See table
Output voltage	$V_H \geq (V_{supply} - 1)$ at $-I_H \leq 10$ mA $V_L \leq 1$ V at $I_L \leq 10$ mA
Resolution	9 bit (512 positions per revolution)
Hysteresis	0.45°
Accuracy	±0.7°
Repeatability	≤ 0.07°
Data outputs	D0 (LSB) - D8 (MSB)
Data input	LE - latch enable input signal, active high Maximum sampling rate 500 kHz
Max. cable length	10 m
Connector options	15 pin 'D' type plug (standard) Flying lead
Temperature	Operating -25 °C to +85 °C 0 °C to +70 °C variant PB Storage -25 °C to +125 °C
Maximum speed	20,000 rpm

Timing diagram

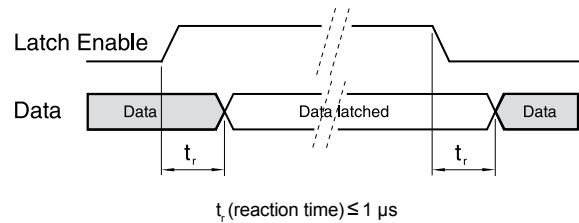

Output type and electrical variant

Variant	Type	Power consumption	Max. load
PA	Push-Pull	40 mA	30 mA
PB	Open Collector NPN	25 mA	20 mA



Position increases for clockwise rotation of shaft

RE36I – Incremental outputs

Square wave output

Power supply	8 V to 26 V = V_{supply}
Power consumption	(at 24 V) See table
Output signals	Variant IA: A, B, Z, A-, B-, Z- (RS422) Variant IB: A, B, Z
Resolution	Variant IB: 128 pulses per revolution (512 counts per revolution with 4x evaluation) Variant IA: 80 to 2,048 pulses per revolution (320, 400, 500, 512, 800, 1,000, 1,024, 1,600, 2,000, 2,048, 4,096, 8,192 counts per revolution)
Max. cable length	20 m
Connector options	9 pin 'D' type plug (standard) Flying lead
Temperature	Operating -25 °C to +70 °C 0 °C to +70 °C variant IB Storage -25 °C to +125 °C

Resolution options (counts per revolution)	Maximum speed (rpm)	Accuracy*	Hysteresis
320, 400, 500	20,000	±0.5°	0.18°
512	20,000	±0.5°	0.45°
800, 1,000, 1,024	20,000	±0.3°	0.18°
1,600, 2,000, 2,048	10,000	±0.3°	0.18°
4,096	5,000	±0.3°	0.18°
8,192	2,500	±0.3°	0.18°

* Worst case within operational parameters including magnet position and temperature.

Timing diagram

(complementary signals not shown)

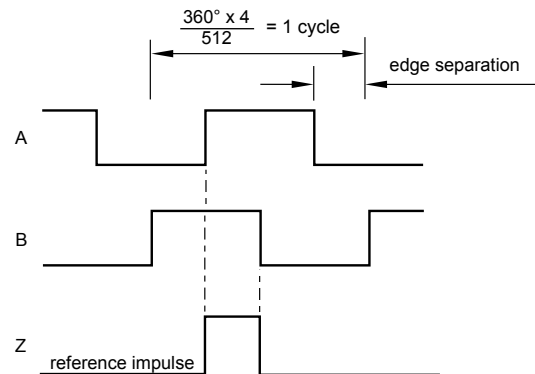

Output type and electrical variant

Variant	Type	Power consumption	Max. load
IA	Push-Pull	30 mA - 9-bit 50 mA - other resolutions	30 mA
IB	Open Collector NPN	25 mA	20 mA



B leads A for clockwise rotation of shaft

Output specifications - 24 V supply

RE36V – Linear voltage output

Power supply	Type I: +20 V to +30 V DC Type II: ±12 V to ±16 V DC
Power consumption	40 mA typical
Output voltage	Type I: 0 V to 10 V DC Type II: -10 V to +10 V DC
Output loading	Max. 10 mA
Nonlinearity	1 %
Max. cable length	20 m
Connector options	9 pin 'D' type plug (standard) Flying lead
Temperature	Operating -25 °C to +70 °C Storage -25 °C to +125 °C
Maximum speed	20,000 rpm

Electrical output/shaft position

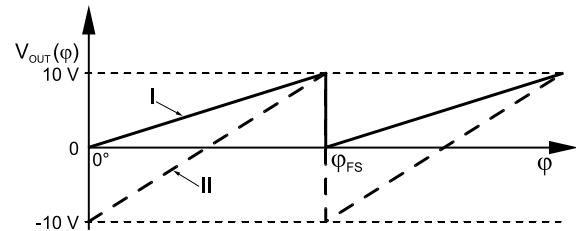

Output type and electrical variant

φ _{FS}	Type I				Type II			
	360°	180°	90°	45°	360°	180°	90°	45°
Clockwise	VA	VB	VC	VD	VM	VN	VP	VQ
Counterclockwise	VE	VF	VG	VH	VR	VS	VT	VV

Image shows clockwise rotation of shaft



RE36C - Linear current output

Power supply	V _{dd} = +20 V to +30 V DC
Power consumption	50 mA plus output current
Output current	Type I: 4 mA to 20 mA Type II: 0 mA to 20 mA
Output loading	R _L = 0 to $\frac{V_{dd}}{I_{OUTmax}}$
Nonlinearity	1 %
Max. cable length	20 m
Connector options	9 pin 'D' type plug (standard) Flying lead
Temperature	Operating -25 °C to +70 °C Storage -25 °C to +125 °C
Maximum speed	20,000 rpm

Electrical output/shaft position

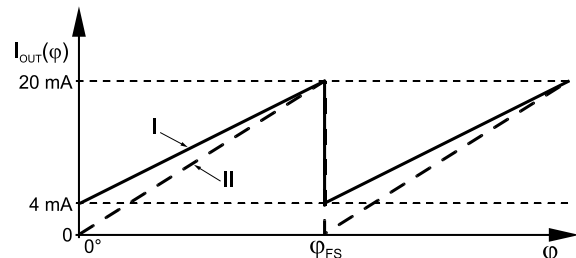

Output type and electrical variant

φ _{FS}	Type I				Type II			
	360°	180°	90°	45°	360°	180°	90°	45°
Clockwise	CA	CB	CC	CD	CM	CN	CP	CQ
Counterclockwise	CE	CF	CG	CH	CR	CS	CT	CV

Image shows clockwise rotation of shaft



RE36 ordering code



Encoder part number
eg RE36SC0612B10A2A00

RE36 SC 06 12B 10 A 2 A 00

Output type

- IA - Incremental, push-pull, 24 V
- IB - Incremental, open collector, 24 V
- IC - Incremental, RS422, 5 V
- SC - Absolute binary synchro-serial (SSI), RS422, 5 V
- SI - SSI and incremental, RS422, 5 V
- PA - Absolute parallel, push-pull, 24 V
- PB - Absolute parallel, open collector, 24 V
- C_x - Linear current:

Linear current output 4 mA to 20 mA, supply +20 V to +30 V DC				
	360°	180°	90°	45°
Clockwise	CA	CB	CC	CD
Counter clockwise	CE	CF	CG	CH
Linear current output 0 mA to 20 mA, supply +20 V to +30 V DC				
	360°	180°	90°	45°
Clockwise	CM	CN	CP	CQ
Counter clockwise	CR	CS	CT	CV

V_x - Linear voltage:

Linear voltage output 0 V to 10 V, supply +20 V to +30 V DC				
	360°	180°	90°	45°
Clockwise	VA	VB	VC	VD
Counter clockwise	VE	VF	VG	VH
Linear voltage output ±10 V, supply ±12 V to ±16 V DC				
	360°	180°	90°	45°
Clockwise	VM	VN	VP	VQ
Counter clockwise	VR	VS	VT	VV

Shaft size
06 - 6 mm

Special requirements

- 00 - None
- 0M - Cable length in meters

Environment

- A - IP53, Aluminium body (standard)
- B - IP64, Aluminium body
- C - IP68, Aluminium body

Body style and cable exit

- 2 - Cylindrical body, radial cable exit

Connector option

- A - 'D' type connector - 9 way
- B - 'D' type connector - 15 way (for output types PA and PB only)
- F - Flying lead (no connector)

Cable length

- 10 - 1.0 meter (10 meters if 0M is chosen)

Resolution

- 09B - 512 counts or positions per revolution

For output types IA, IC, SC and SI:

Decimal			Binary	
D32 - 320	D80 - 800	2D0 - 2000	09B - 512	12B - 4096
D40 - 400	1D0 - 1000		10B - 1024	13B - 8192
D50 - 500	1D6 - 1600		11B - 2048	

NOTE: Not all combinations are valid.

Head office

RLS merilna tehnika d.o.o.
Poslovna cona Žeje pri Komendi
Pod vrbami 2
SI-1218 Komenda
Slovenia

T +386 1 5272100
F +386 1 5272129
E mail@rls.si
www.rls.si

Document issues

Issue	Date	Page	Corrections made
1	13. 1. 2009	-	New layout

RENISHAW  is our worldwide sales support partner for Magnetic Encoders.

Australia
T +61 3 9521 0922
E australia@renishaw.com

Austria
T +43 2236 379790
E austria@renishaw.com

Brazil
T +55 11 4195 2866
E brazil@renishaw.com

Canada
T +1 905 828 0104
E canada@renishaw.com

The People's Republic of China
T +86 10 8448 5306
E beijing@renishaw.com

Czech Republic
T +420 5 4821 6553
E czech@renishaw.com

France
T +33 1 64 61 84 84
E france@renishaw.com

Germany
T +49 7127 9810
E germany@renishaw.com

Hong Kong
T +852 2753 0638
E hongkong@renishaw.com

Hungary
T +36 23 502 183
E hungary@renishaw.com

India
T +91 20 6674 6751
E india@renishaw.com

Israel
T +972 4 953 6595
E israel@renishaw.com

Italy
T +39 011 966 10 52
E italy@renishaw.com

Japan
T +81 3 5366 5316
E japan@renishaw.com

The Netherlands
T +31 76 543 11 00
E benelux@renishaw.com

Poland
T +48 22 577 11 80
E poland@renishaw.com

Russia
T +7 495 231 1677
E russia@renishaw.com

Singapore
T +65 6897 5466
E singapore@renishaw.com

Slovenia
T +386 1 52 72 100
E mail@rls.si

South Korea
T +82 2 2108 2830
E southkorea@renishaw.com

Spain
T +34 93 663 34 20
E spain@renishaw.com

Sweden
T +46 8 584 90 880
E sweden@renishaw.com

Switzerland
T +41 55 415 50 60
E switzerland@renishaw.com

Taiwan
T +886 4 2473 3177
E taiwan@renishaw.com

UK
T +44 1453 524524
E uk@renishaw.com

USA
T +1 847 286 9953
E usa@renishaw.com

**For all other countries
Please contact RLS' head
office**

T +386 1 52 72 100
E mail@rls.si