

QG series

QG40N-KDXYh-090-AI-CM

Inclination sensor 2 axis horizontal mounting

Output
4 - 20 mA

Supply voltage
10 - 30V dc

Measuring range
 $\pm 90^\circ$



QG40N-KDXYh-090-AI-CM

Housing
Dimensions (indicative)
Mounting
Ingress Protection (IEC 60529)
Relative humidity
Weight
Supply voltage
Polarity protection
Current consumption
Operating temperature
Storage temperature
Measuring range
Centering function
Frequency response (-3dB)
Accuracy (2 σ)
Offset error
Non linearity
Sensitivity error
Resolution
Temperature coefficient
Max mechanical shock
Output
Output load
Short circuit protection
Output refresh rate

General specifications v20151221

Plastic injection molded housing (Quadro40, PBTP black)
40x40x25 mm
2x M3x25 mm zinc plated steel pozidrive screws included
IP67
0 - 100%
ca 45 gr
10 - 30V dc
Yes
≤ 15 mA (excluding output signal)
-25 .. +85°C
-40 .. +85°C
$\pm 90^\circ$
Yes (12 mA = 0°), range: $\pm 5^\circ$
10 Hz
overall 0,4° typ.
$< \pm 0,2^\circ$ (after centering)
$< \pm 0,4^\circ$
not applicable
0,09°
$\pm 0,04^\circ/\text{K}$ typ.
10.000g
4 - 20 mA
Rload $\leq (50^\circ\text{Vs}-300)$ [Ω] (Eg: Vs = 24 V: Rload $\leq 900 \Omega$)
Yes (max 10 s)
20 ms

QG40N-KDXYh-090-AI-CM

$I_{out} = 12 + 8(\alpha/90)$ [mA]
clipping outside measuring range

Transfer characteristic

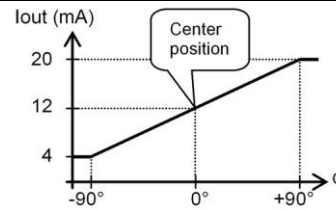

QG40N-KDXYh-090-AI-CM

Default 0°: horizontal, no acceleration applied.
Cross tilt sensitivity error:
 $< (0,12 * \text{cross tilt angle})^2$ % typ.
Note:
one axis $< 10^\circ$ tilt for max. accuracy
Note:
only one axis may exceed 45° tilt

Measurement orientation

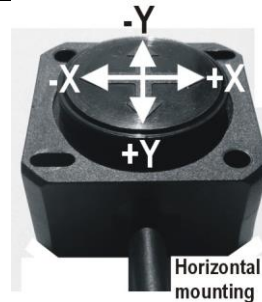

QG40N-KDXYh-090-AI-CM

Connection

Wire / pin coding

Connectivity (length $\pm 10\%$)

M12 5p male connector (Glass fibre reinforced grade, contacts CuZn pre-nickeled galv. Au)

Pin 1: + Supply Voltage
Pin 2: output Y
Pin 3: Gnd
Pin 4: output X
Pin 5: Centering

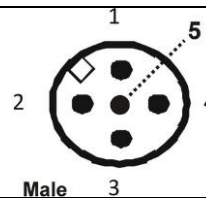

QG40N-KDXYh-090-AI-CM

Mechanical dimensions (indicative only)

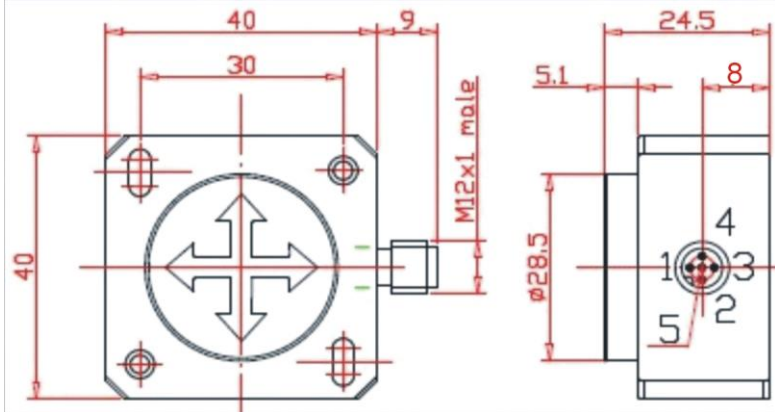

QG40N-KDXYh-090-AI-CM

Center function

Centering can be done to eliminate mechanical offsets.
To execute centering connect center input to ground ($>0,5\text{sec}$) within 1 min. after power up.
After centering you have 1 min. left for another centering.
Normally the center input should be left unconnected.