

LSW Series

DC-Operated, Gravity-Referenced
Weather Proof Servo Inclinometer

Features

- Weatherproof to IP67* – stainless steel construction
- Waterproof moulded cable system – field replaceable
- Fully self-contained - connect to a DC power source and a readout or control device for a complete operating system
- High-level DC output signal proportional to sine of the angle of tilt
- $\pm 3^\circ$ to $\pm 90^\circ$ ranges available
- Extremely rugged, withstands 1500g shock

Applications

- Bore-hole mapping, dam and rock shifts and other geophysical and seismic studies
- Offshore
- Military
- Civil Engineering

The LSW Series are high precision closed loop gravity referenced tilt sensors designed for demanding all-weather applications. The sensor is constructed from stainless steel and features a moulded IP68 connector/cable system that can be field replaced if the cable becomes damaged. Models are available in a variety of angular ranges.

Pin 1 (Brown)	: +12V to +18V dc
Pin 2 (White)	: Output
Pin 3 (Blue)	: 0V
Pin 4 (Black)	: -12V to -18V dc

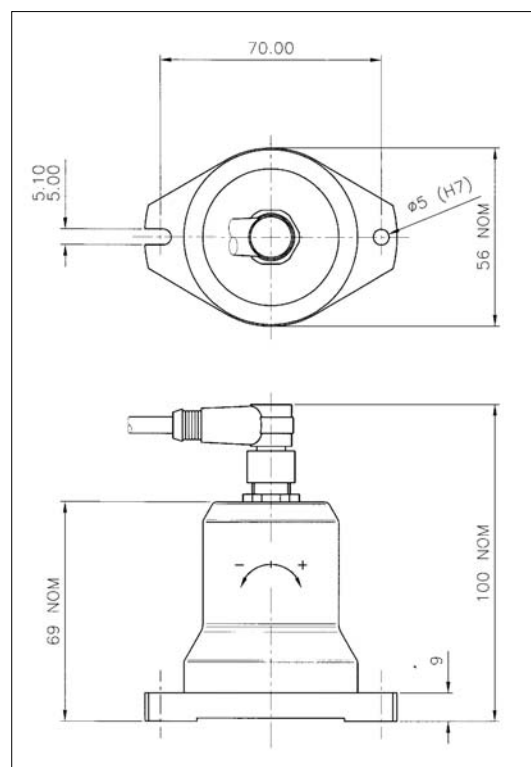

LSW Series

DC-Operated, Gravity-Referenced
Weather Proof Servo Inclinometer

Performance Specifications @ 20°C					
Range		± 3°	± 14.5°	± 30°	± 90°
Excitation Voltage	Volts dc	±12 to ±18			
Current Consumption	mA (nom)	±15			
Full Range Output (FRO) (see note 1)	Volts dc	±5			
Output Standardisation	% FRO	±1			
Output Impedance	Ω (max)	10			
Output Noise (DC to 10kHz)	Vrms (max)	0.002			
Non-Linearity (see note 2)	% FRO	0.05	0.02	0.02	0.05
Non-Repeatability	% FRO	0.01	0.002	0.001	0.0005
Resolution	Arc seconds	0.2	1.0	2.0	4.0
-3 dB Frequency	Hz	15	30	40	55
Sensitive Axis to Case Misalignment	Deg (max)	±0.15	±0.25	±0.50	±1.0
Cross Axis Sensitivity (see note 3)	% FRO (max)	0.2			
Zero Offset (see note 4)	Volts dc	±0.04	±0.04	±0.02	±0.02
Thermal Zero Shift	% FRO/°C	±0.03	±0.01	±0.005	±0.003
Thermal Sensitivity Shift	% Reading/°C	±0.03	±0.01	±0.006	±0.006

Environmental Specifications		
EMC Directive	EN61326: 1998	
EMC Emissions	EN55022: 1998	30 MHz to 1 GHz
EMC Immunity	EN61000-4-2: 1995 inc A1: 1998 & A2: 2001	±4 kV
	EN61000-4-3: 2002	10 V/m
	EN61000-4-4: 2004	± 1 kV
	EN61000-4-6: 1996 inc A1: 2001	3 Vrms
	EN61000-4-6: 2007	10 Vrms
	EN61000-4-8: 1994 inc A1: 2001	30 A/m
Constant Acceleration Overload	50g	
Shock Survival	1500g, 0.5 ms, ½ sine	
Vibration Endurance	35g RMS, 20 Hz to 2000 Hz sinusoidal	
Environmental Sealing	IP65	

Notes	
1.	Full Range Output is defined as the full angular excursion from positive to negative, i.e. ±90° = 180°
2.	Non-linearity is determined by the method of least squares.
3.	Cross axis sensitivity is the output of the unit when tilted to full range angle in cross axis
4.	Zero offset is specified under static conditions with no vibration inputs

How To Order: Example LSW -14.5

LSW -14.5 is a standard LSW series sensor with a range ± 14.5°



In North America: Email: nasales@sherbornesensors.com
Rest of World: Email: sales@sherbornesensors.com
Website: www.sherbornesensors.com



Sherborne Sensors, a Nova Metrix company

