



955A BRIK Gen III

Gemco Series 955A BRIK Gen III

The 955A BRIK Gen III is an accurate programmable, auto-tuning, non-contact, linear displacement transducer in an economical, low profile package. The transducer utilizes our field proven magnetostrictive technology to give absolute position, repeatable to .006% of the programmable sensing distance.

The streamlined anodized aluminum extrusion houses the sensing element and electronics. The magnet moves over the sensing element that determines the position and converts it to an analog output. It can be ordered with a 0 to 10 VDC or 4 to 20 mA output.

The 955A BRIK Gen III has a few truly unique features. The first one is the LDT's auto-tuning capability, the ability to sense a magnet other than the standard slide magnet and adjust its signal strength accordingly. Another feature is the analog output is programmable over the entire active stroke length. The active stroke area of the LDT lies between the Null and Dead zones. There is a diagnostic LED located at the connector end of the probe that remains green while a good magnet signal is present and when the magnet is in the programmed stroke area. The LED turns yellow when the magnet is out of the programmed active range, but still within the active stroke area. The LED turns red and the output goes to 0 volts on voltage output units, or 4 mA on current output units when there is no magnet present or when the magnet is out of the sensing area. The unit can easily be changed in the field from a 0 - 10 VDC to a 10 - 0 VDC or 4 - 20 mA to a 20 - 4 mA. As an added feature, the optional differential analog output allows the distance between two magnets to be measured.

The 955A BRIK is designed for applications where economical continuous feedback is necessary. The sensor can be a cost effective replacement to limit switches, proximity sensors, linear potentiometers and LVDT's. Applications include presses, blow molding, injection molding, extrusion, roll positioning, dancer control and many more.



955

Specifications	
Input Voltage	13.5 to 30 VDC
Current Draw	2.5 Watts Maximum, 120 mA @ 15 VDC Typical
Output	0 to 10 VDC, 10 to 0 VDC, 4 to 20 mA, 20 to 4 mA
Resolution 1) Internal 2) Analog Output	0.001" 16 Bit (1 part in 65,535)
Non-Linearity	+/- 0.05% of Stroke
Repeatability	+/- 0.006% of Full Stroke
Hysteresis	+/- 0.02% of Full Scale
Update 50" or less 51" to 100" 101" to 150" 151" to 180"	1mS (Stroke Lengths 5" - 50") 2mS (Stroke Lengths 51" - 100") 3mS (Stroke Lengths 101" - 150") 4mS (Stroke Lengths 151" - 180")
Operating Temperature	-20° to 70° C
Span Length	5" to 180"
Null Zone	3.00"
Dead Zone	2.00"
LED	Green = Power is applied and magnet is present Red = Fault, magnet is in the Dead Zone or lost Yellow = Out of the active programmed range
Connector	Standard 5 Pin Micro 12mm Euro Connector
Approvals	CE
Enclosure	IP67, IP68 Optional
Specifications are subject to change without notice. Specifications are based on a typical 36" LDT.	

Part Numbering

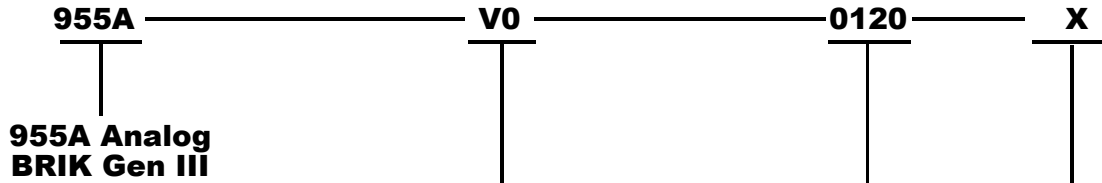

Output Type

- V0 = 0 - 10 VDC
- V1 = 10 - 0 VDC
- C4 = 4 to 20 mA
- C2 = 20 to 4 mA
- D0 = Differential 0 - 10 VDC*
- D1 = Differential 4 - 20 mA *

*Analog differential output is the difference between two magnets. Minimum distance is 2.5".

Stroke in Inches

Insert stroke in inches to 0.1 inch. Enter as a four-place number. **Example:** 12.0 in stroke entered as 0120. To convert a metric stroke in millimeters, multiply millimeter value by 0.03937 to arrive at inch value.

Options

- X = No options
- E = Wet environment. Electronics sealed to IP 68 Rating.

Wiring Diagram

Use Euro Connector (micro 12 mm single keyway) cordsets, available from most connector manufacturers or purchased from Ametek. Install according to the following diagram:

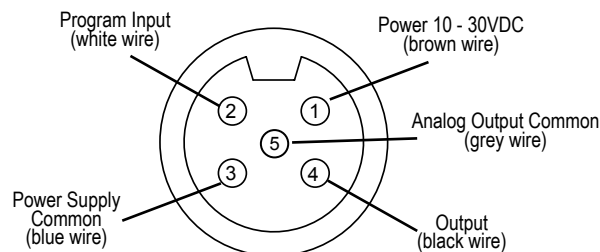

Connector View

Accessories

Item	Part Number
Slide Magnet	SD0521800
Float Magnet	SD0522100
Mounting Foot	SD0522000
6 Ft. Cable	949019L6
12 Ft. Cable	949019L12
6 Ft. Cable; Right Angle Connector	949020L6
12 Ft. Cable; Right Angle Connector	949020L12

Dimension Drawing

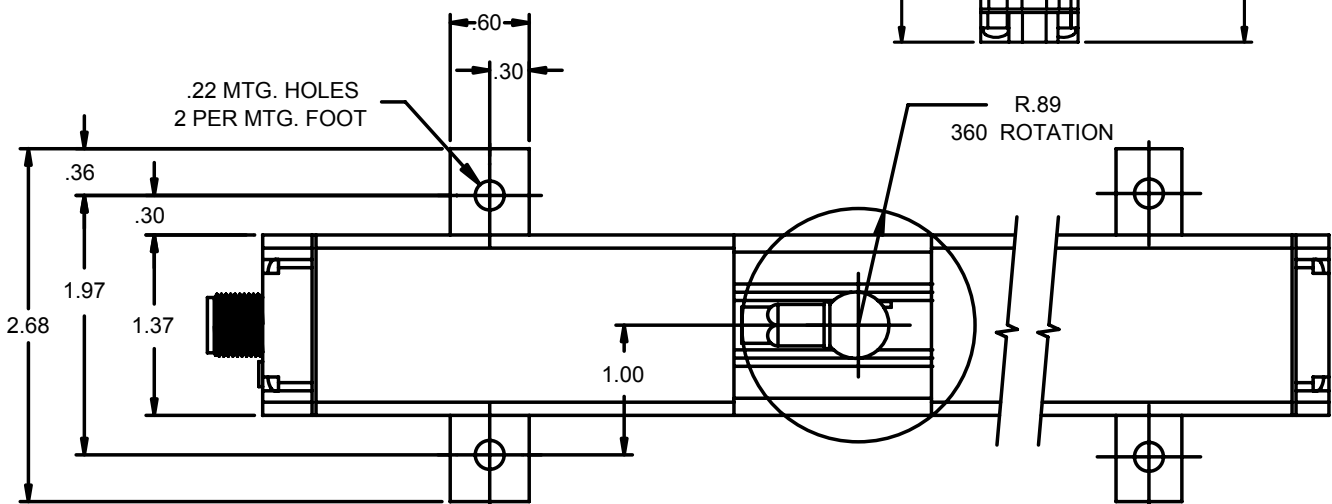
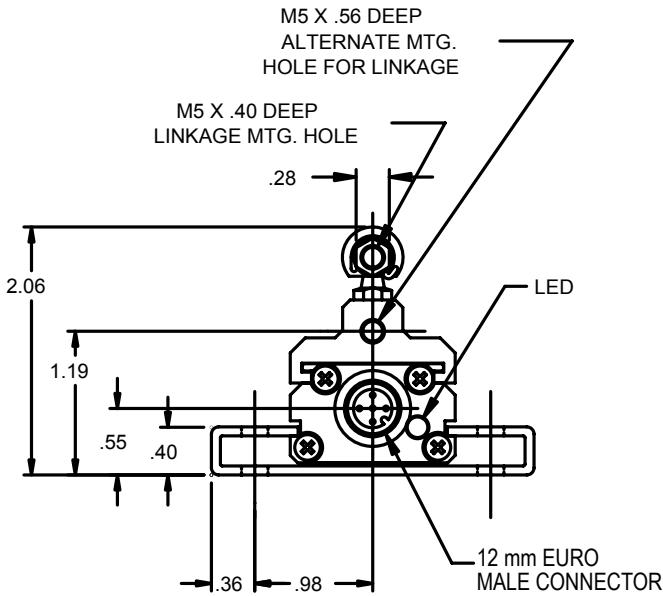
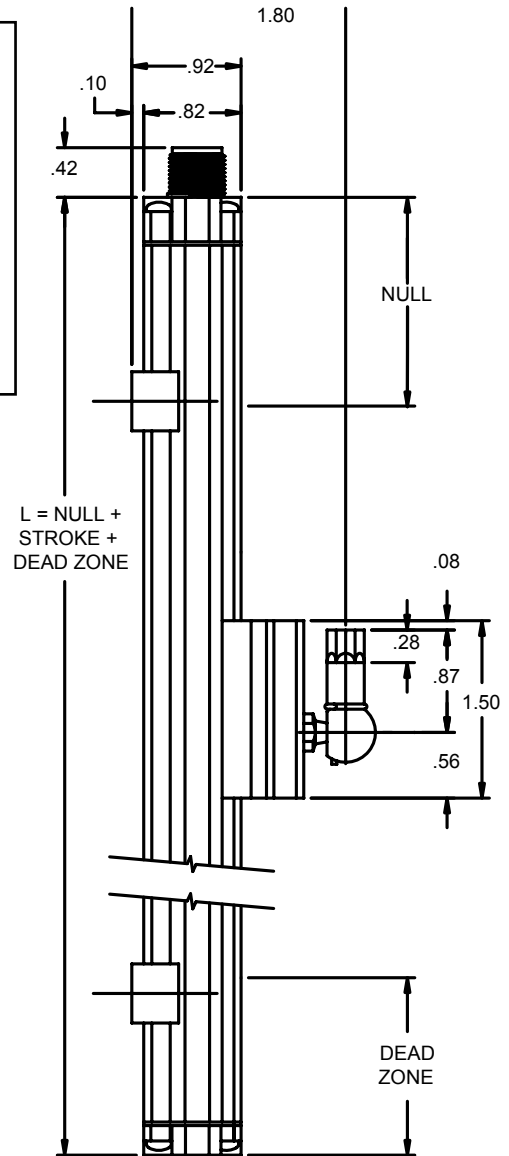
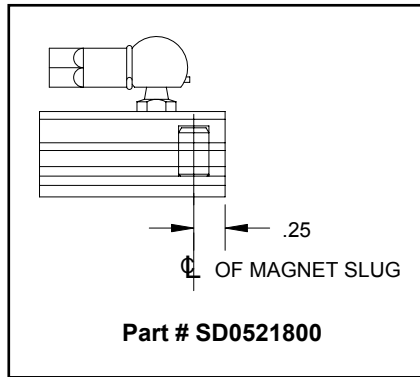
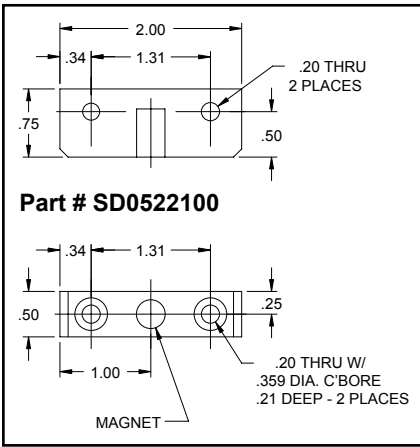

955